



Rewarding Learning

General Certificate of Secondary Education  
2022

Centre Number

--	--	--	--	--

Candidate Number

--	--	--	--

# GCSE Chemistry

Unit 2

Foundation Tier



[GCM21]

\*GCM21\*

**MONDAY 20 JUNE, MORNING**

## TIME

1 hour 15 minutes.

## INSTRUCTIONS TO CANDIDATES

Write your Centre Number and Candidate Number in the spaces provided at the top of this page.

**You must answer the questions in the spaces provided.**

**Do not write outside the boxed area on each page or on blank pages.**

Complete in black ink only. **Do not write with a gel pen.**

Answer **all six** questions.

## INFORMATION FOR CANDIDATES

The total mark for this paper is 80.

Figures in brackets printed down the right-hand side of pages indicate the marks awarded to each question or part question.

Quality of written communication will be assessed in Question **3(f)(iii)**.

A Data Leaflet, which includes a Periodic Table of the Elements, is included in this question paper.

12895



\*20GCM2101\*

1 Dilute hydrogen peroxide solution is a mild antiseptic which can be used on the skin to prevent infection of minor cuts. Hydrogen peroxide decomposes at room temperature and releases oxygen. The release of oxygen causes foaming which helps to remove dead skin and clean the cut.

(a) The diagram below shows some of the apparatus used in the laboratory to investigate the rate of reaction for the decomposition of hydrogen peroxide.

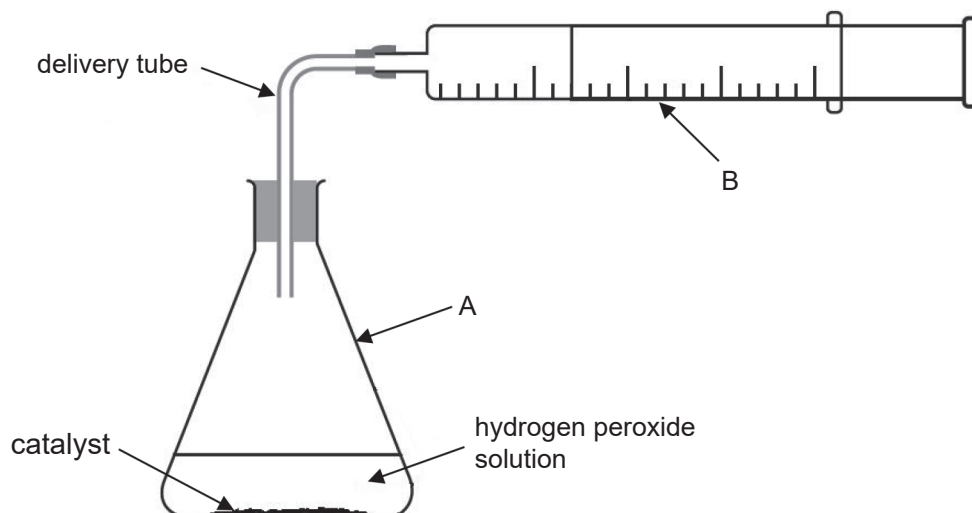

(i) Name the pieces of apparatus labelled A and B.

A \_\_\_\_\_

B \_\_\_\_\_ [2]

(ii) Name one other piece of apparatus which the student must use in order to investigate the rate of reaction for the decomposition of hydrogen peroxide.

\_\_\_\_\_ [1]



(iii) Name a catalyst which can be used to increase the rate of decomposition of hydrogen peroxide.

\_\_\_\_\_ [1]

(iv) Which one of the following statements explains how a catalyst increases the rate of a chemical reaction? Place a tick (✓) in the right-hand box to indicate the correct statement.

The catalyst provides an alternative reaction pathway

The catalyst provides more energy for the reactant molecules

The catalyst makes the reaction exothermic

[1]

(v) Describe a test for oxygen gas.

\_\_\_\_\_

\_\_\_\_\_ [2]

[Turn over



(b) The results obtained from the experiment in (a) are shown in the table below.

Time /s	0	10	20	30	40	50	60	70	80	90
Volume of oxygen /cm <sup>3</sup>	0	60	90	105	112	116	118	120	120	120

(i) Plot the results on the axes below.

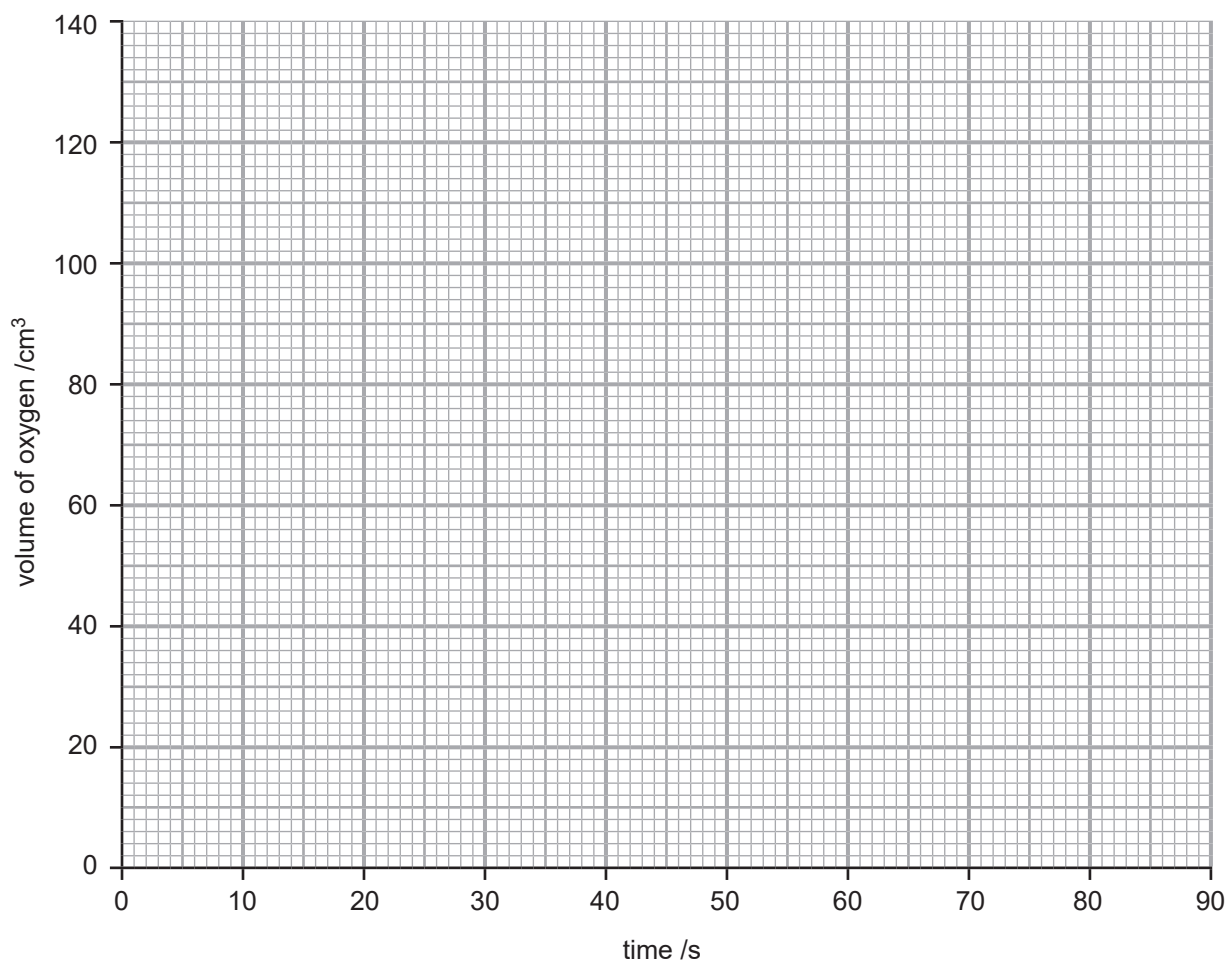

[3]



- (ii) Use your graph to determine the volume of oxygen gas collected in the first 12 seconds.

\_\_\_\_\_ [1]

- (iii) Use your graph to determine the time taken to collect 100 cm<sup>3</sup> of oxygen gas.

\_\_\_\_\_ [1]

- (iv) State the time at which the reaction stopped.

\_\_\_\_\_ [1]

- (c) Hydrogen peroxide may be manufactured by reacting barium peroxide, BaO<sub>2</sub>, with cold dilute sulfuric acid. The equation for the reaction is:

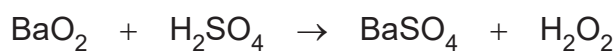

Using the equation given below, calculate the percentage atom economy of hydrogen peroxide in this reaction. Give your answer to 1 decimal place.

$$\% \text{ atom economy} = \frac{\text{mass of desired product}}{\text{total mass of products}} \times 100$$

percentage atom economy = \_\_\_\_\_ % [2]

[Turn over



- 2 Nitrogen monoxide reacts with oxygen to form nitrogen dioxide as shown in the equation below. A dynamic equilibrium is established.

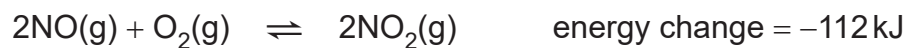

- (a) State two features of a dynamic equilibrium.

---

---

---

---

[2]

- (b) What is the energy change of the reverse reaction?

---

[1]



(c) The table below shows the percentage yield of nitrogen dioxide at different temperatures.

Temperature / °C	100	200	300	400
Percentage yield of NO <sub>2</sub> at equilibrium / %	98	92	85	76

(i) Use the data in the table to state the effect of an increase in temperature on the percentage yield of NO<sub>2</sub>.

\_\_\_\_\_ [1]

(ii) Apart from temperature, state one other factor which could alter the direction of a reversible reaction.

\_\_\_\_\_ [1]

[Turn over



3 Ethane, ethene and ethanol belong to different homologous series. Ethane is a saturated hydrocarbon, ethene is an unsaturated hydrocarbon and ethanol is an alcohol.

(a) State two features of a homologous series of organic compounds.

---

---

---

---

[2]

(b) What is the functional group of the alkenes?

---

[1]

(c) Explain why ethene is an **unsaturated hydrocarbon**.

---

---

---

---

[2]

(d) Suggest why alkanes are less reactive than alkenes.

---

---

[1]



(e) Ethene can undergo a polymerisation reaction to make the polymer, polythene. Polythene may be disposed of in landfill sites or by incineration.

(i) What is meant by the term polymerisation?

---

---

[2]

(ii) What is meant by the term incineration?

---

[1]

(iii) Place one tick (✓) in each column in the table below to indicate one advantage and one disadvantage of disposing of polythene in landfill sites.

	Advantage	Disadvantage
It releases energy		
It wastes land		
It produces carbon dioxide		
It is inexpensive		

[2]

[Turn over



(f) Alcohols such as ethanol and propan-1-ol are colourless liquids.

(i) Draw the structural formulae of ethanol and propan-1-ol.

ethanol

propan-1-ol

[2]

(ii) Name another alcohol which has the same molecular formula as propan-1-ol.

[1]





4 25.0 cm<sup>3</sup> of sodium hydroxide solution of known concentration were placed in a conical flask. Three drops of substance **A** were added to the conical flask. A titration was carried out by adding sulfuric acid to the conical flask.

(a) In addition to a retort stand, clamp and conical flask, name three essential pieces of equipment needed to carry out a titration.

---

---

---

[2]

(b) Identify **A** by placing a circle around the name of one substance from the list below.

blue litmus      bromine water      methyl orange      universal indicator

[1]

(c) The titration was carried out three times. State one variable that needs to be kept the same to ensure a fair test.

---

[1]



(d) The results of the titration are shown in the table below.

	Initial burette reading /cm <sup>3</sup>	Final burette reading /cm <sup>3</sup>	Titre /cm <sup>3</sup>
Rough titration	0.0	18.5	18.5
First accurate titration	18.5	36.5	
Second accurate titration	0.0	18.2	

(i) Complete the table. [2]

(ii) Calculate the average titre and state its units.

[2]

[Turn over



5 Nearly 75% of the elements in the Periodic Table are classified as metals. These metals show different reactivities.

(a) In an experiment, a small piece of metal was added to a fixed volume of water and the time taken for the reaction to finish was recorded. The results are shown in the table below.

Metal	Time taken for reaction to finish /s
calcium	42
lithium	35
magnesium	Not finished after 300 s
potassium	5
sodium	11

(i) Write a word equation for the reaction of potassium with water.

\_\_\_\_\_ [2]

(ii) A few drops of phenolphthalein were added to the solution produced when potassium reacted with water. State the colour observed.

\_\_\_\_\_ [1]

(iii) Describe, in terms of electrons, what happens to the potassium atoms when they react with water.

\_\_\_\_\_  
\_\_\_\_\_  
\_\_\_\_\_ [2]



(iv) Compare the reactivity of Group 1 and Group 2 metals. Give evidence from the table to support your answer.

---

---

---

---

[2]

[Turn over

12895



\*20GCM2115\*

- (b) When a mixture of iron(III) oxide and aluminium powder is reacted in the apparatus shown below, a bright flame and sparks are observed. Molten iron is formed.

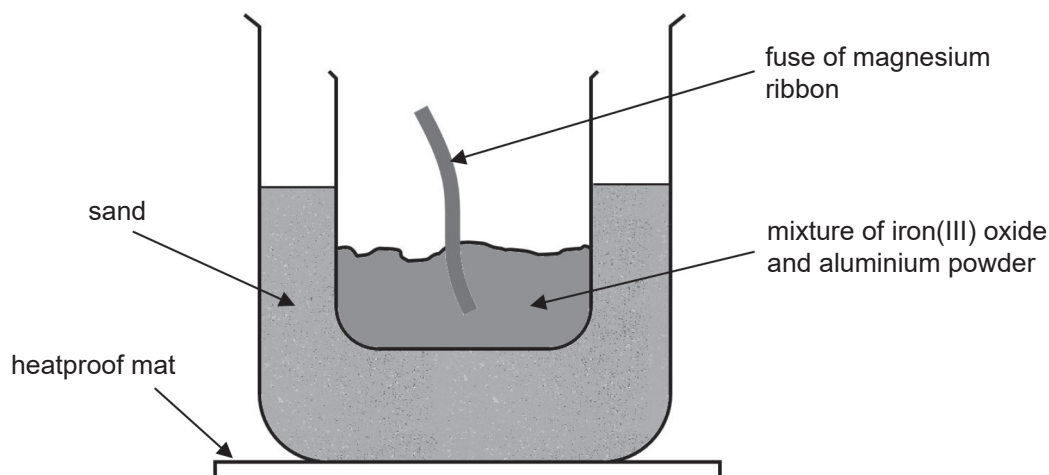

- (i) Complete the sentences below by putting a circle around the correct word or phrase in each sentence.

To start the reaction, bonds need to **break / form**.

To start the reaction, energy is **taken in / given out**.

Overall energy is given out, therefore the reaction is **exothermic / endothermic**.

During the reaction **more / less** energy is taken in than given out. [4]

- (ii) Explain, in terms of reactivity, why the reaction of iron(III) oxide with aluminium occurs.

---

---

[1]



(c) Lead can be extracted from lead(II) oxide using carbon in a furnace. The word equation for the reaction is:

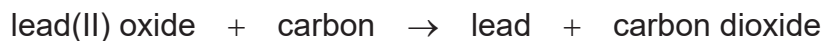

(i) Write a balanced symbol equation for this reaction.

\_\_\_\_\_ [3]

(ii) Explain fully, in terms of change in oxygen content, why this reaction is described as a redox reaction.

\_\_\_\_\_  
\_\_\_\_\_  
\_\_\_\_\_  
\_\_\_\_\_  
\_\_\_\_\_  
\_\_\_\_\_  
\_\_\_\_\_ [5]

[Turn over



**6 (a)** Electrolysis occurs when molten sodium chloride conducts electricity.

**(i)** What is meant by the term electrolysis?

\_\_\_\_\_  
\_\_\_\_\_ [1]

**(ii)** Explain why molten sodium chloride conducts electricity.

\_\_\_\_\_  
\_\_\_\_\_ [1]

**(iii)** What is observed at the anode?

\_\_\_\_\_ [2]

**(iv)** Name a suitable material used for the electrodes.

\_\_\_\_\_ [1]

**(b)** Aluminium may be extracted from its ore by electrolysis. The ore of aluminium is purified to form aluminium oxide (alumina). The alumina is dissolved in molten cryolite and the electrolysis is carried out.

**(i)** Name the ore from which aluminium is extracted.

\_\_\_\_\_ [1]

**(ii)** State two reasons why aluminium oxide is dissolved in molten cryolite.

1. \_\_\_\_\_

\_\_\_\_\_

2. \_\_\_\_\_

\_\_\_\_\_ [2]



(iii) Name the electrolysis products formed at the anode and at the cathode.

anode: \_\_\_\_\_

cathode: \_\_\_\_\_ [2]

(iv) Explain why the anode has to be replaced periodically.

\_\_\_\_\_

\_\_\_\_\_

\_\_\_\_\_ [2]

---

**THIS IS THE END OF THE QUESTION PAPER**

---



**Sources:**

Q1.....CCEA AS/A2 Practical Chemistry by Alyn McFarland (9781510448018) 2019 © Hodder Education.  
"Reproduced with permission of the Licensor through PLSclear."

All other images © CCEA

**DO NOT WRITE ON THIS PAGE**

For Examiner's use only	
Question Number	Marks
1	
2	
3	
4	
5	
6	

<b>Total Marks</b>	
--------------------	--

Examiner Number

Permission to reproduce all copyright material has been applied for.  
In some cases, efforts to contact copyright holders may have been unsuccessful and CCEA will be happy to rectify any omissions of acknowledgement in future if notified.

GCM21/6  
258532



## SYMBOLS OF SELECTED IONS

### Positive ions

Name	Symbol
Ammonium	$\text{NH}_4^+$
Chromium(III)	$\text{Cr}^{3+}$
Copper(II)	$\text{Cu}^{2+}$
Iron(II)	$\text{Fe}^{2+}$
Iron(III)	$\text{Fe}^{3+}$
Lead(II)	$\text{Pb}^{2+}$
Silver	$\text{Ag}^+$
Zinc	$\text{Zn}^{2+}$

### Negative ions

Name	Symbol
Butanoate	$\text{C}_3\text{H}_7\text{COO}^-$
Carbonate	$\text{CO}_3^{2-}$
Dichromate	$\text{Cr}_2\text{O}_7^{2-}$
Ethanoate	$\text{CH}_3\text{COO}^-$
Hydrogencarbonate	$\text{HCO}_3^-$
Hydroxide	$\text{OH}^-$
Methanoate	$\text{HCOO}^-$
Nitrate	$\text{NO}_3^-$
Propanoate	$\text{C}_2\text{H}_5\text{COO}^-$
Sulfate	$\text{SO}_4^{2-}$
Sulfite	$\text{SO}_3^{2-}$



## Data Leaflet

### Including the Periodic Table of the Elements

For the use of candidates taking  
 Science: Chemistry,  
 Science: Double Award  
 or Science: Single Award

### SOLUBILITY IN COLD WATER OF COMMON SALTS, HYDROXIDES AND OXIDES

Soluble
All sodium, potassium and ammonium salts
All nitrates
Most chlorides, bromides and iodides EXCEPT silver and lead chlorides, bromides and iodides
Most sulfates EXCEPT lead and barium sulfates Calcium sulfate is slightly soluble
Insoluble
Most carbonates EXCEPT sodium, potassium and ammonium carbonates
Most hydroxides EXCEPT sodium, potassium and ammonium hydroxides
Most oxides EXCEPT sodium, potassium and calcium oxides which react with water

Copies must be free from notes or additions of any kind. No other type of data booklet or information sheet is authorised for use in the examinations

# gcse examinations chemistry

